



TRAILER REFRIGERATION / CONTAINER REFRIGERATION
GOVI BRINGS INNOVATION AND
FRESHNESS ON THE ROAD



LIKE A DREAM
COME TRUE



I had a vision from the beginning of my career:

I wanted to design, develop and produce a useful, reliable and quality product which is at the same time aesthetically pleasing to the eye. A great high-quality product my customers would appreciate.

Establishing GOVI GmbH in 2002 I came a step closer to realising my dream.

Together with my strong, reliable and dedicated team consisting of technicians, engineers and commercial specialists, I've built and launched a range of trailer and container refrigeration units. Today our refrigeration units are globally known for their excellent quality.

We continuously enhance the quality of our products by selecting the best suppliers. The most economic solution is not always the best! We will not compromise on quality. We appreciate our employees and invest in their development and sustainability. We rely on a state-of-the-art production to deliver excellence to our customers.

I'm proud of our achievements since 2002. We deliver refrigeration units on 4 continents to more than 25 countries.

Lamberto Govi
Managing Director & Founder

arktik[®]

SMART COOLING

Enable your customers to control the temperature inside of the trailer. No matter where you are, no matter for what you might need it. Smart cooling with GOVI **arktik[®]** maintains the exact level of temperature as required.

Our refrigeration units are designed to endure harsh climate conditions and delivered plug-and-play. Easy and fast assembly provides excellent usability.



arktik[®] units are durable and highly reliable. One step to install the refrigeration units in the trailer. Long durability regardless of wind and weather.

GOVI[®]
GmbH





MOTIVATION RESULTS IN QUALITY

GOVI refrigeration units are designed and made in Germany. One important aspect in the high quality of our products is the employees. Our team works jointly on improving the products and work in a family environment. To ensure a excellent facilities for the growing workforce we moved to a new spacious and state of the art production site in Troisdorf in Autumn 2015.

Our highly motivated employees handle the production of each unit with extreme precision. They focus on meticulously executing each production step, as if it was for the first time. Every unit is tested it thoroughly before it leaves the factory.

We guarantee quality along the value chain. From production to delivery we are a reliable partner.



At GOVI the Managing Director works hand in hand with everyone including the apprentice to cater our clients around the globe with products of high usability and of high quality.

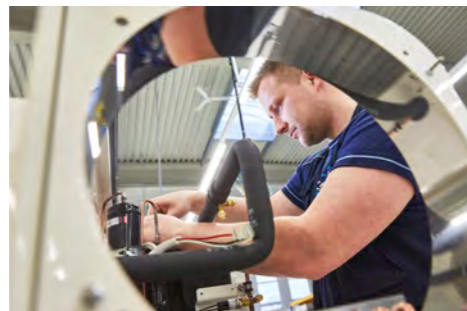



TRAILER REFRIGERATION

Customers who want to install a refrigeration unit on their trailer find at GOVI what they need. Our portfolio offers durable weather-resistant products.

- ✓ robust and durable
- ✓ reliable
- ✓ 230 V -> standard voltage
- ✓ plug and play
- ✓ excellent usability
- ✓ one fixing size for all refrigeration units 1600 N to 2500 N
- ✓ cooling / heating 2000 P/K - 2500 N/K
- ✓ retro-fitting possible
- ✓ easy handling
- ✓ easy to maintain
- ✓ low maintenance
- ✓ rotary compressor

Looking back at our broad experience in the refrigeration industry we know about the critical components in this area. We use the best components to set benchmarks for refrigeration units.

Independent of outside temperatures you reach temperatures between -20 °C to +10 °C.



CONTAINER REFRIGERATION

We developed GOVI Container Refrigeration for larger volume. Available in a variety of sizes and models for all climatic conditions.

We offer tailor-made solutions according to your needs. Please contact us.

- ✓ cooling / heating
- ✓ efficient hot gas defrosting
- ✓ rotary compressor
- ✓ appealing design



We innovate and continuously improve the technology of the suction gas-cooled rotary compressor, the core of **arktik®**. We focus on sustainability and eco-friendly products and work constantly on increasing energy efficiency.



TRAILER REFRIGERATION

GOVI refrigeration units are made for stationary refrigerated trailers.

Our refrigeration units are designed to cover almost all purposes of food and grocery cooling. It cools prepared buffets for caterers and party services. It also can be applied for beverage refrigerated trailers.

Cooling capacity spans from 1600 Watt to 2500 Watt to cover insulated trailers with a volume of 12 or 27 m³. Accurate control provides continuous cooling and freshness to the goods.

Groups

The units consist of 2 groups: an outside condenser and an evaporator inside the trailer. Both components are built on an insulating panel and form the plug-and-play unit.

We use the same chassis for all refrigeration units to standardise size of the fixing hole for the refrigerated trailer. The chassis is made of powder-coated steel panel with a pleasing front cover made of ABS plastic.

An electrical control monitors and adjusts inside temperature. Electrical defrosting with programmable thermostat ensures automated periodic defrosting.

Behind the operating cover is a control switch and a light switch for the inside light of the refrigeration trailer.

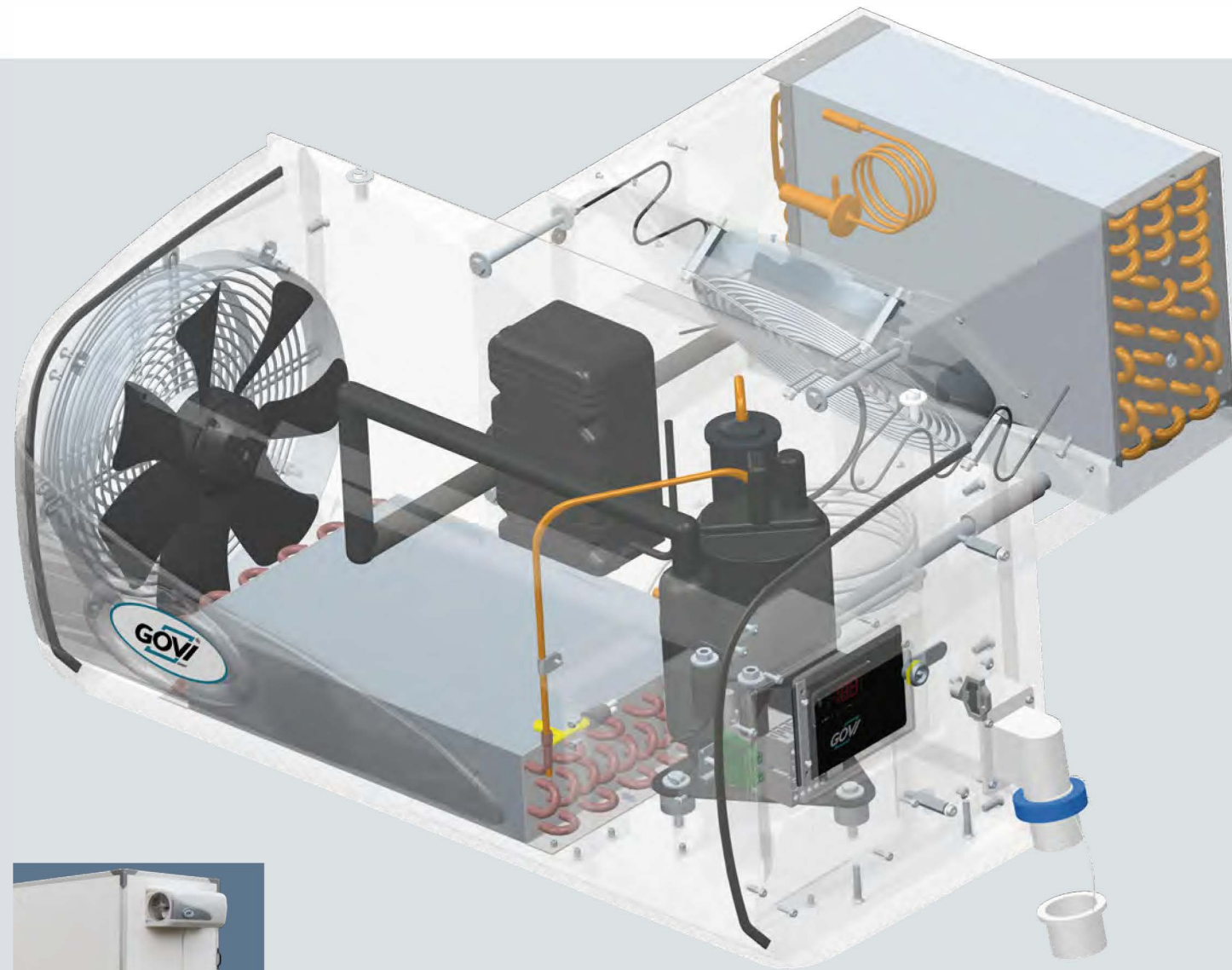

Serial equipment:

- automated defrosting
- suction cooled compressor
- light
- prewired cord to connect door contact switch
- prewired cord to connect light
- weatherproof electrical plug and socket
- thermometer to meter the inside temperature
- lockable control panel

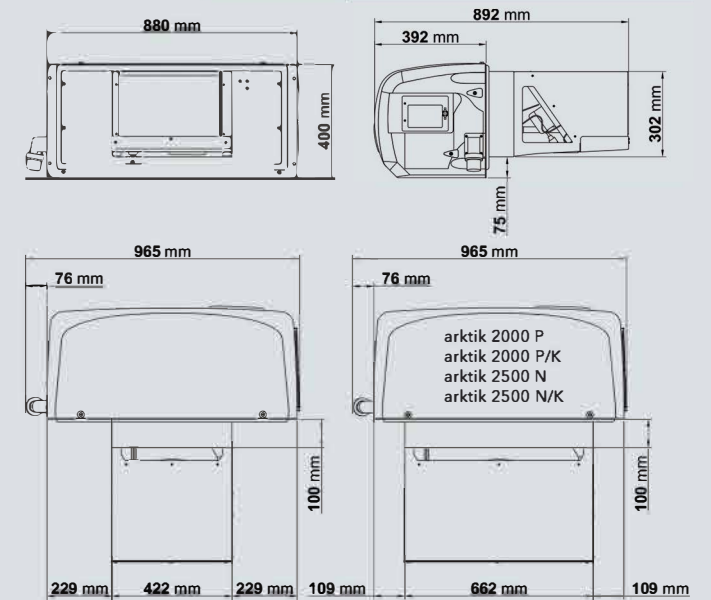

Your Benefits

- special development for trailer
- fast, easy installation
- low weight (from 55 kg)
- suction gas cooled rotary compressor
- quiet operation
- weather-resistant, robust construction
- long durability
- elegant, timeless design
- weatherproof electrical plug and socket
- lockable control panel
- electronic digital thermostat
- automatic defrosting
- easy handling and usability
- also available with heating (Arktik 2000 P/K and Arktik 2500 P/K)
- quality "made in Germany"

| description | unit | arktik® 1600N | arktik® 1600N/T | arktik® 2000N | arktik® 2500N | arktik® 2500N/K | arktik® 2000P | arktik® 2000P/K |
|---|-------------------|---------------|-----------------|---------------|---------------|-----------------|-------------------|-------------------|
| refrigerated trailer internal temperature | °C | T=2 °C | T=2 °C | T=2 °C | T=2 °C | T=2 °C | T=2 °C/ -20 °C | T=2 °C/ -20 °C |
| power supply | V | 230 | 230 | 230 | 230 | 230 | 230 | 230 |
| frequency | Hz | 50 | 50 | 50 | 50 | 50 | 50 | 50 |
| cooling capacity | W | 1600 | 1470* | 2050 | 2500 | 2500 | 1500/2050 | 1500/2050 |
| heating capacity | W | | | | -/- | 1600 | -/- | 1600 |
| power consumption | W | 855 | 855 | 1260 | 1200 | 1200 | 1000/1200 | 1000/1200 |
| current consumption LRA | A | 19,8 | 19,8 | 29 | 32 | 32 | 32 | 32 |
| current consumption FLA | A | 4,8 | 4,8 | 5,7 | 7 | 7 | 6,5/7,0 | 6,5/7,0 |
| defrosting | W | 340 | 340 | 340 | 600 | 600 | 1230 | 1230 |
| air flow evaporator | m ³ /h | 750 | 750 | 750 | 1100 | 1100 | 1100 | 1100 |
| air flow condenser | m ³ /h | 750 | 1100 | 1100 | 1100 | 1100 | 1100 | 1100 |
| protection class, mounting side | IP | 54 | 54 | 54 | 54 | 54 | 54 | 54 |
| refrigerant | Typ | R134a | R134a | R134a | R452A | R452A | R452A | R452A |
| refrigerant quantity | g | 450 | 450 | 550 | 800 | 800 | 1170 | 1170 |
| max. operating temperature | °C | 40 | 45 | 40 | 40 | 40 | 40 | 40 |
| dimensions | mm | See drawing | See drawing | See drawing | See drawing | See drawing | See drawing | See drawing |
| weight | kg | 55 | 55 | 63 | 63 | 63 | 63 | 63 |
| max. volume trailer | m ³ | 12 | 10 | 19 | 25 | 25 | 10 | 10 |

Refrigerant R134a CFC-free • refrigerant R452A CFC-free • N = normal temperature • N/T = normal temperature at high outside temperature
 P = Polytemperatur • K = Heating (ensuring the desired temperature in winter)
 Refrigeration capacity is based on the following operating conditions: outside temperature 30 °C, RH 50 % •* outside temperature 40 °C, RH 50 %
 We recommend an insulation with a k-value of 0,2W/m²K

CONTAINER REFRIGERATION

GOVI container refrigeration units are made for stationary containers

Cooling capacity spans from 4050 Watt to refrigerate containers with a volume up to 30 m³. Accurate control provides continuous cooling and freshness to the goods.

Groups

The units consist of 2 groups: an outside condenser and an evaporator inside the container. Both components are built on an insulating panel and form the plug-and-play unit.

We use the same chassis for all refrigeration units to standardise size of the fixing hole for the refrigeration trailer. The chassis is made of powder-coated steel panel with a pleasing front cover made of ABS plastic.

An electrical control monitors and adjusts inside temperature. Hot gas defrosting with programmable thermostat ensures automated periodic defrosting.

Behind the operating cover is a master switch and a light switch for the inside light of the container.

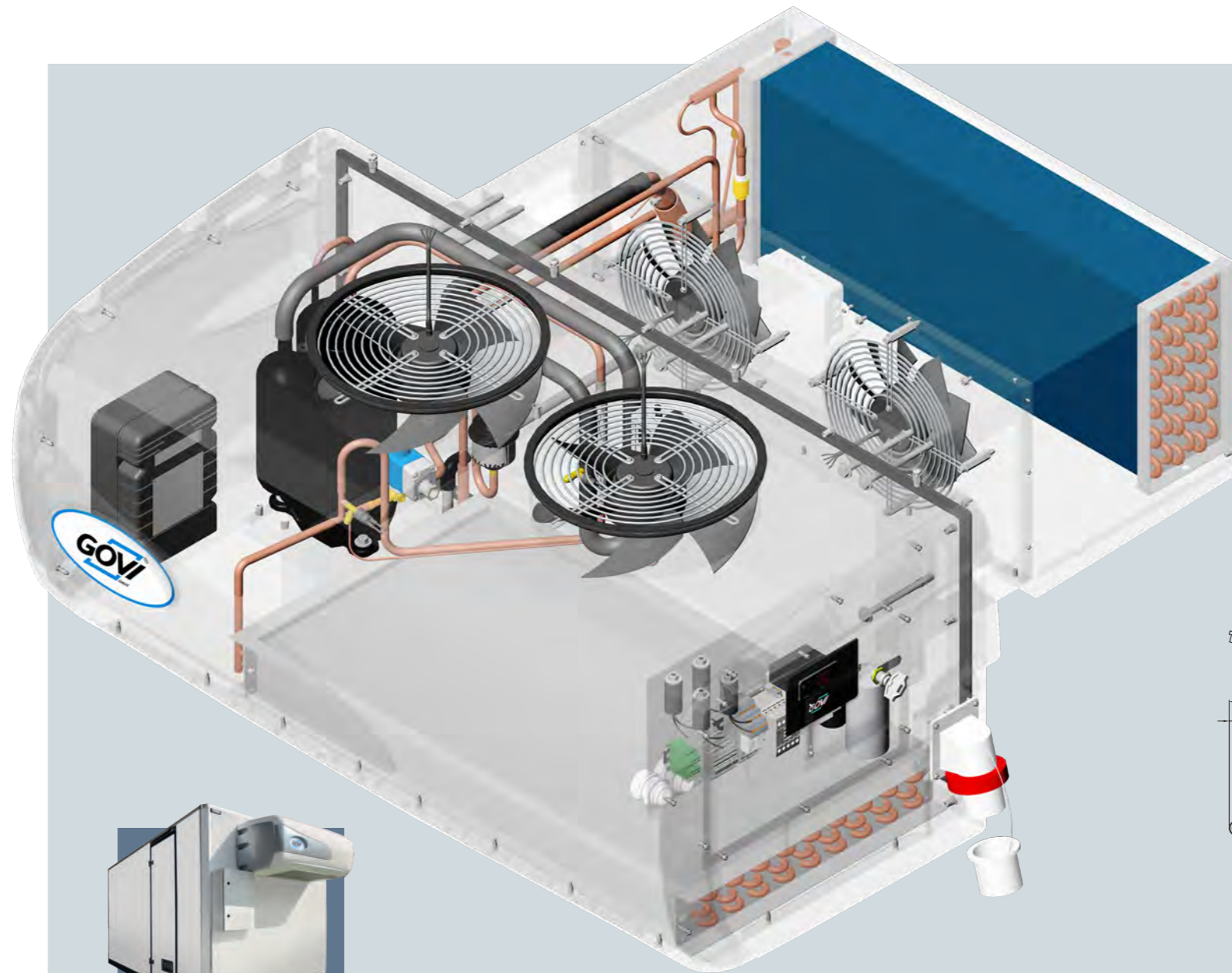

Serial equipment:

- automatic hot gas defrosting
- suction gas cooled compressor
- prewired cord to connect light
- socket with coupling
- thermometer to meter the inside temperature
- lockable control panel

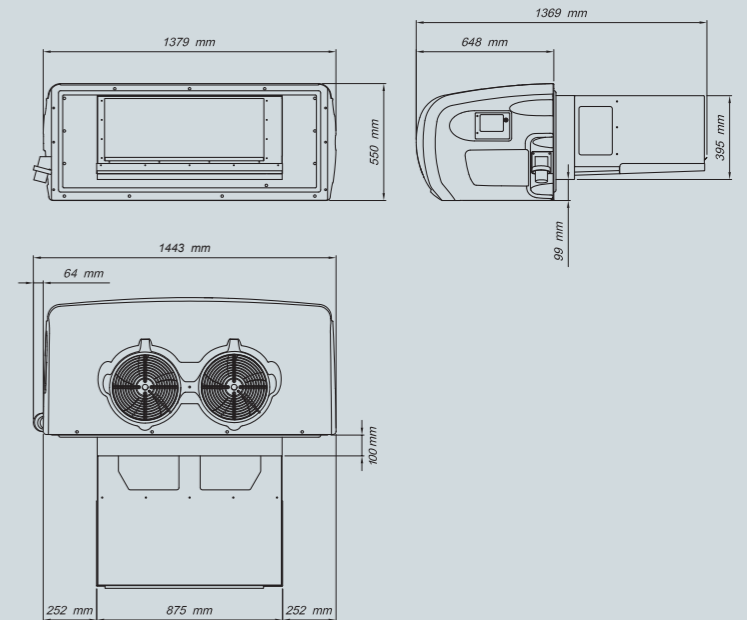

Your Benefits

- developed for container
- fast and easy installation
- low weight (from 163 kg)
- suction gas cooled rotary compressor
- silent operation
- weather-resistant, robust construction
- high durability
- elegant, timeless design
- weatherproof electrical plug and socket
- lockable control panel
- electronic digital thermostat
- automated defrosting
- simple handling and usability
- available with heating
- quality „made in Germany“

| description | unit | arktik® 2000T | arktik® 4000N | arktik® 4000N/K |
|---|-------------------|------------------|------------------|--------------------|
| refrigerated container internal temperature | | T= -20 °C | T=2 °C | T=2 °C |
| power supply | V | 400/3~ | 400/3~ | 400/3~ |
| frequency | Hz | 50 | 50 | 50 |
| cooling capacity | W | 2050 | 4050 | 4050 |
| heating capacity | W | -/- | -/- | 3200 |
| power consumption | W | 2500 | 2850 | 2850 |
| current consumption LRA | A | 54 | 54 | 54 |
| current consumption FLA | A | 9,8 | 12 | 12 |
| defrosting | | Hot gas | Hot gas | Hot gas |
| air flow evaporator | m ³ /h | 3270 | 3270 | 3270 |
| air flow condenser | m ³ /h | 4200 | 4200 | 4200 |
| protection class, mounting side | IP | 54 | 54 | 54 |
| refrigerant | Typ | R452A | R452A | R452A |
| refrigerant quantity | g | 2400 | 2400 | 2400 |
| max. operating temperature | °C | 40 | 40 | 40 |
| dimensions | mm | See drawing | See drawing | See drawing |
| weight | kg | 163 | 163 | 163 |
| max. volume container | m ³ | 20 | 32 | 32 |

Refrigerant R134a CFC-free • refrigerant R452A CFC-free • N = normal temperature • N/T = normal temperature at high outside temperature
 P = Polytemperatur • K = Heating (ensuring the desired temperature in winter) • T = freezer temperature
 Refrigeration capacity is based on the following operating conditions: outside temperature 30 °C, RH 50 % • outside temperature 40 °C, RH 50 %
 We recommend an insulation with a k-value of 0,2W/m²K

GOVI AROUND THE GLOBE



GOVI GmbH

Max-Planck-Str. 5

53842 Troisdorf (Germany)

Phone: +49(0)2241-92 29 460

Fax: +49(0)2241-92 30 390

email: info@govi-gmbh.de

www.govi-gmbh.de

